

# Service Schematics

## NOKIA 6131/6133

RM-115

## NOKIA 6133/6126

RM-126

## Introduction

### IMPORTANT:

This document is intended for use by authorized NOKIA service centers only.

“Service Schematics” was created with focus on customer care. The purpose of this document is to provide further technical repair information for NOKIA mobile phones on Level 3/4 service activities. It contains additional information such as e.g. “Component finder”, “Frequency band table” or “Antenna switch table”. The “Signal overview” page gives a good and fast overview about the most important signals and voltages on board. Saving process time and improving the repair quality is the aim of this document. It is to be used additionally to the service manual and other training or service information such as Service Bulletins.

All measurements were made using following equipment:

Nokia repair SW	: Phoenix version 2006.04.6.130
Oscilloscope	: Fluke PM 3380A/B
Spectrum Analyzer	: Advantest R3162 with an analog probe
RF-Generator / GSM Tester	: Rhode & Schwarz CMU 200
Multimeter	: Fluke 73 Series II

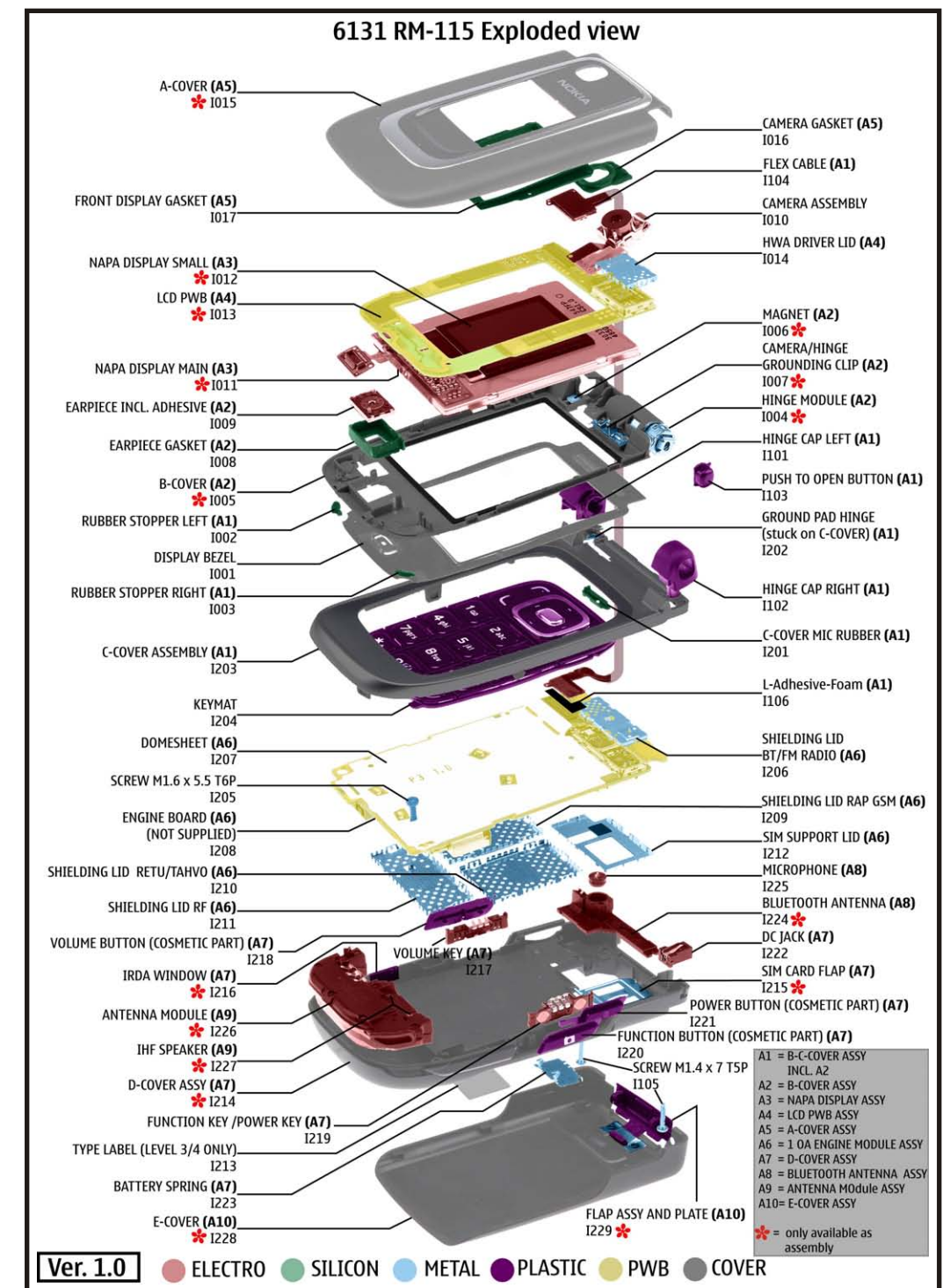

Table of Contents	Page
Front page	1
System connector	2
RETU, SIM, Audio	3
TAHVO	4
RAPGSM, Combo memory, IrDA	5
FM radio, Bluetooth	6
UI	7
Camera, Earpiece, LCD interface	8
RF part	9
Signal overview	10
Component finder lower block	11
Component finder upper block	12

Copyright © NOKIA

This material, including documentation and any related computer programs is protected by copyright, controlled by NOKIA. All rights are reserved. Copying, including reproducing, modifying, storing, adapting or translating any or all of this material requires the prior written consent of NOKIA. This material also contains confidential information, which may not be disclosed to others without the prior written consent of NOKIA.

## Exploded view and component disposal



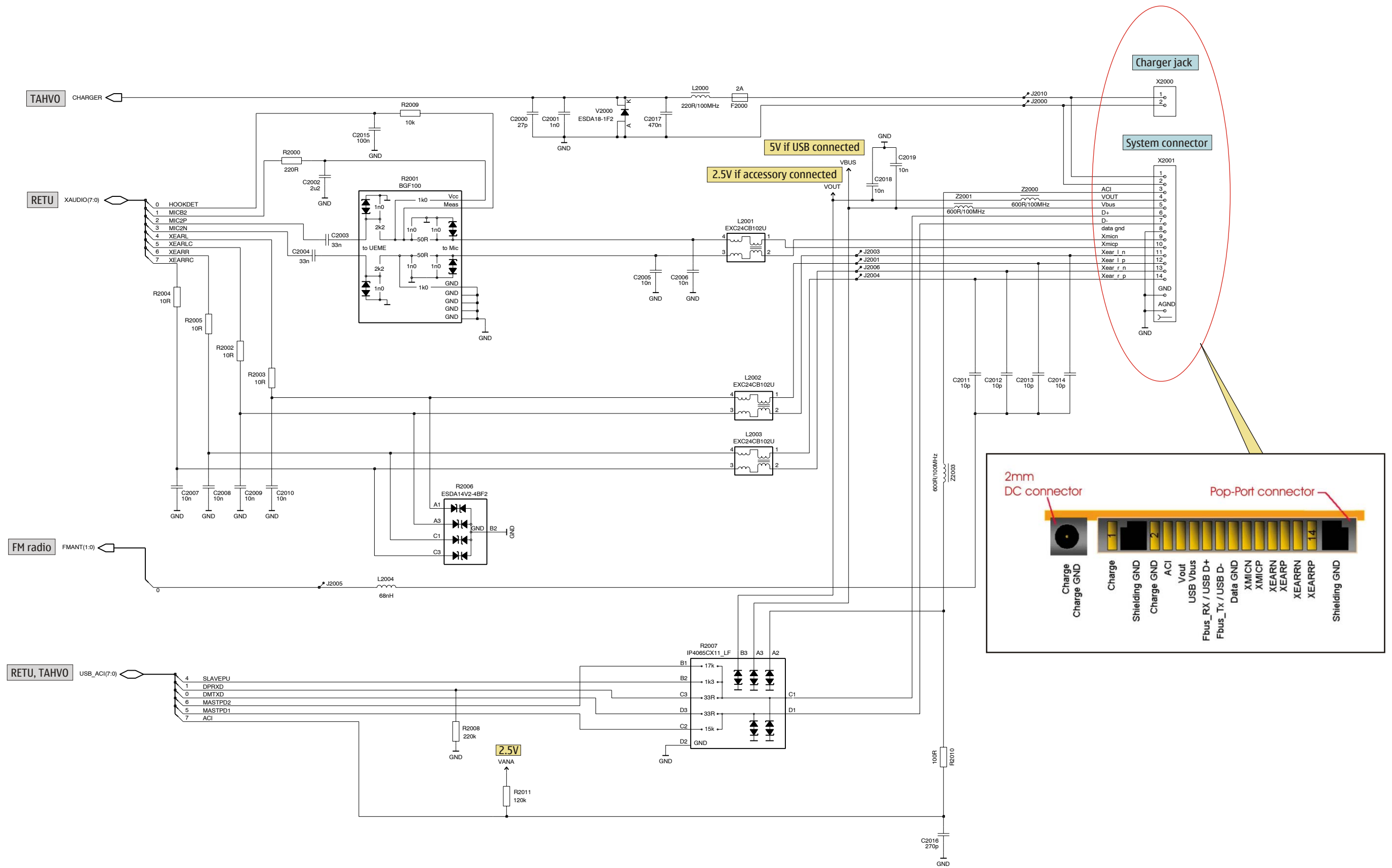

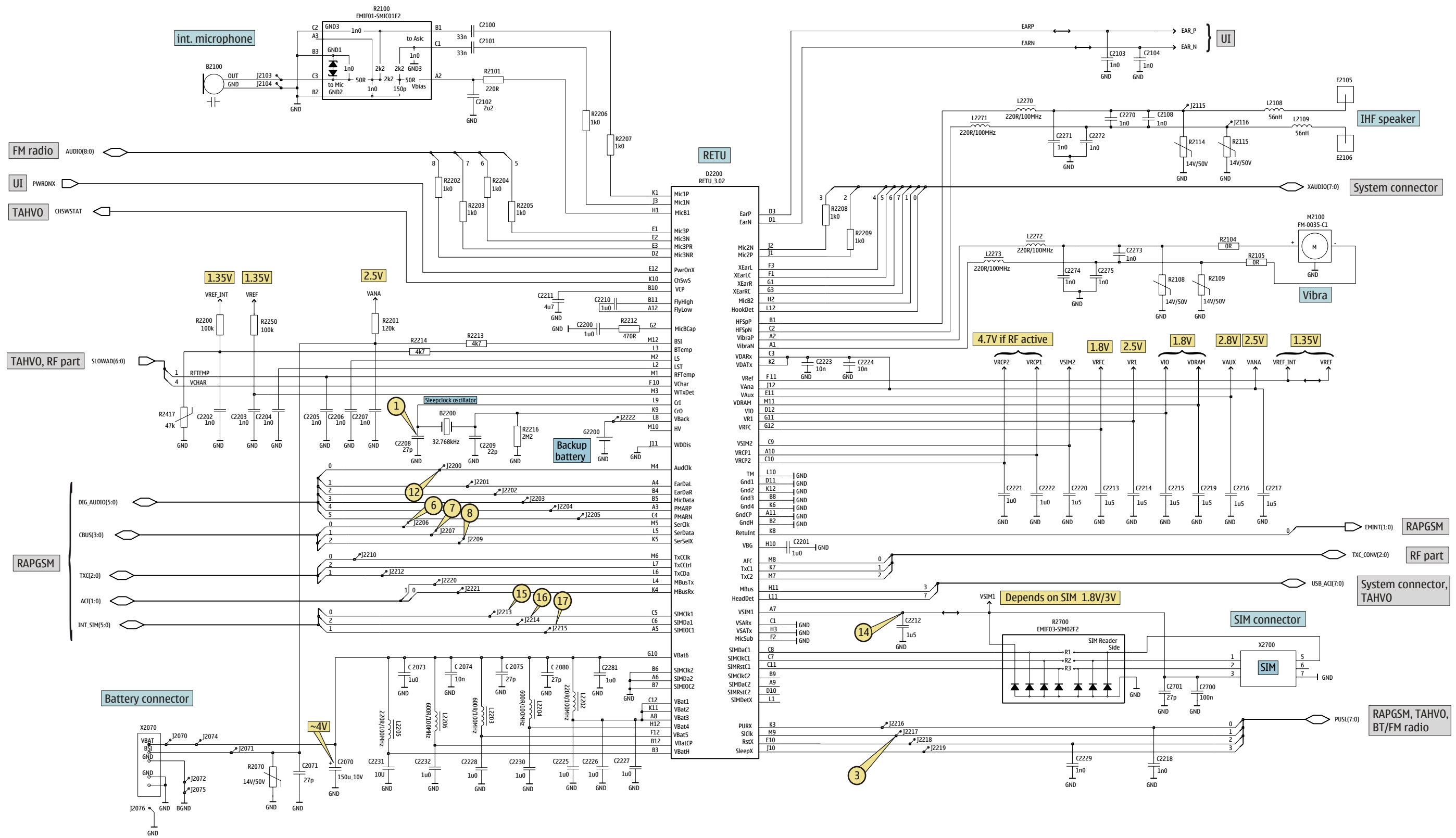

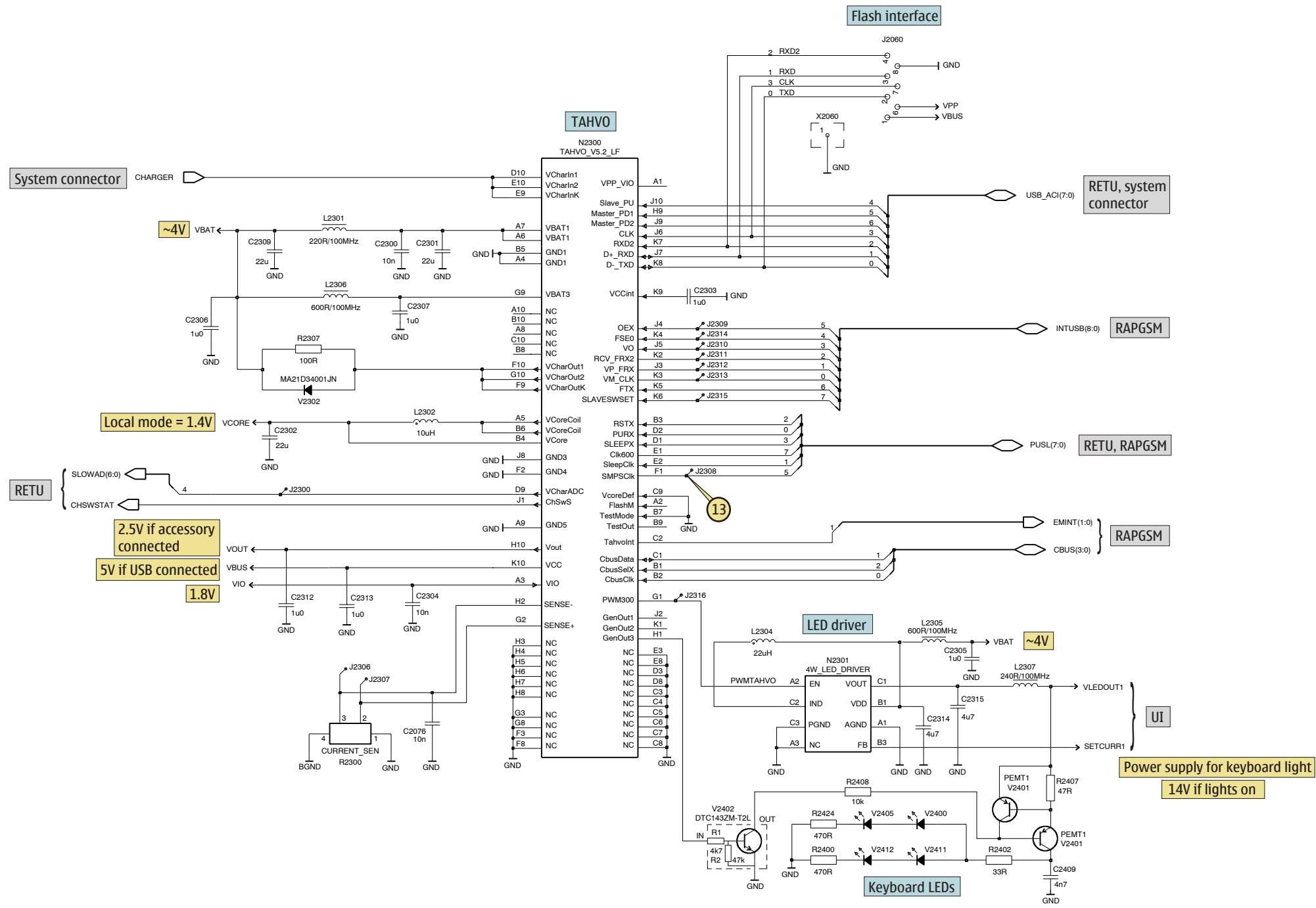

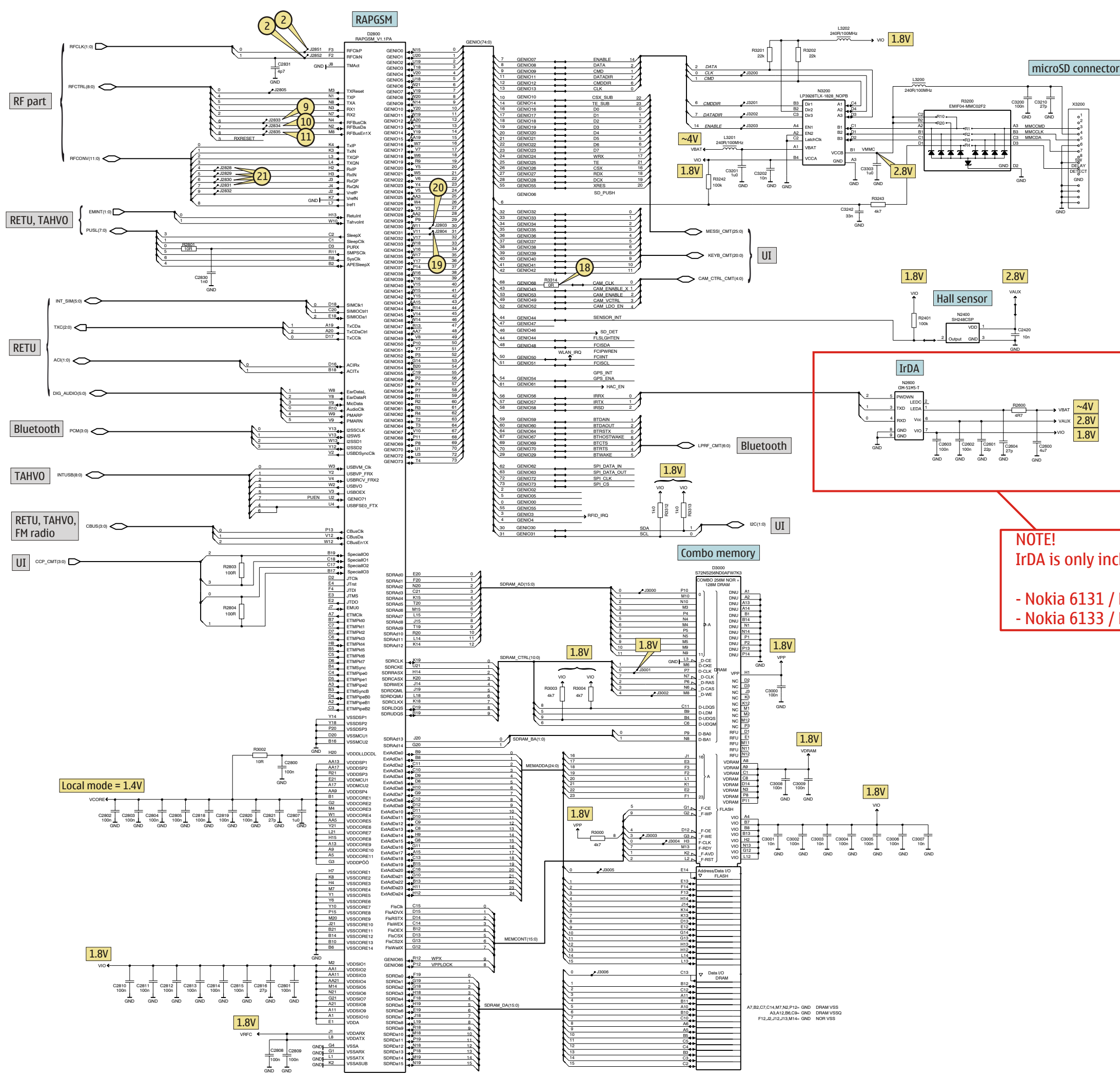

**NOTE!**  
IrDA is only included in  
- Nokia 6131 / RM-115  
- Nokia 6133 / RM-115

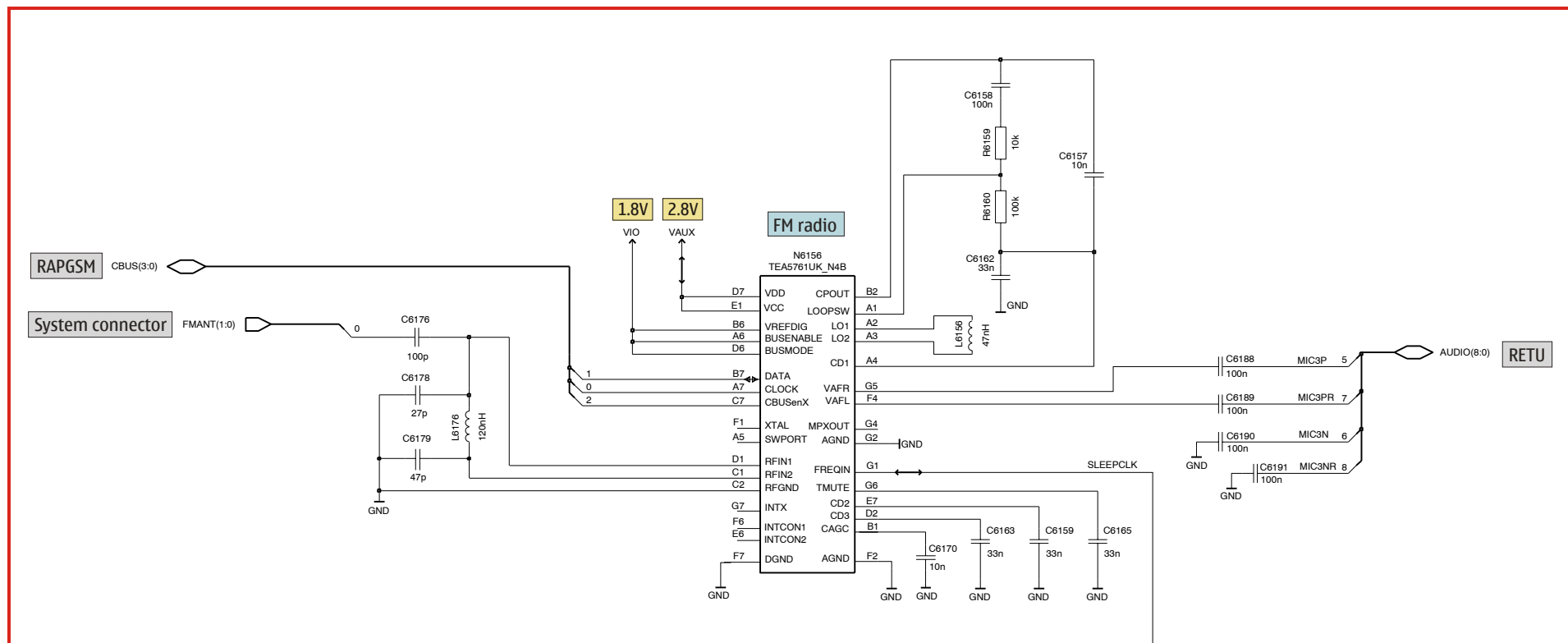

**NOTE!**  
 FM radio is only included in

- Nokia 6131 / RM-115
- Nokia 6133 / RM-115
- Nokia 6133 / RM-126

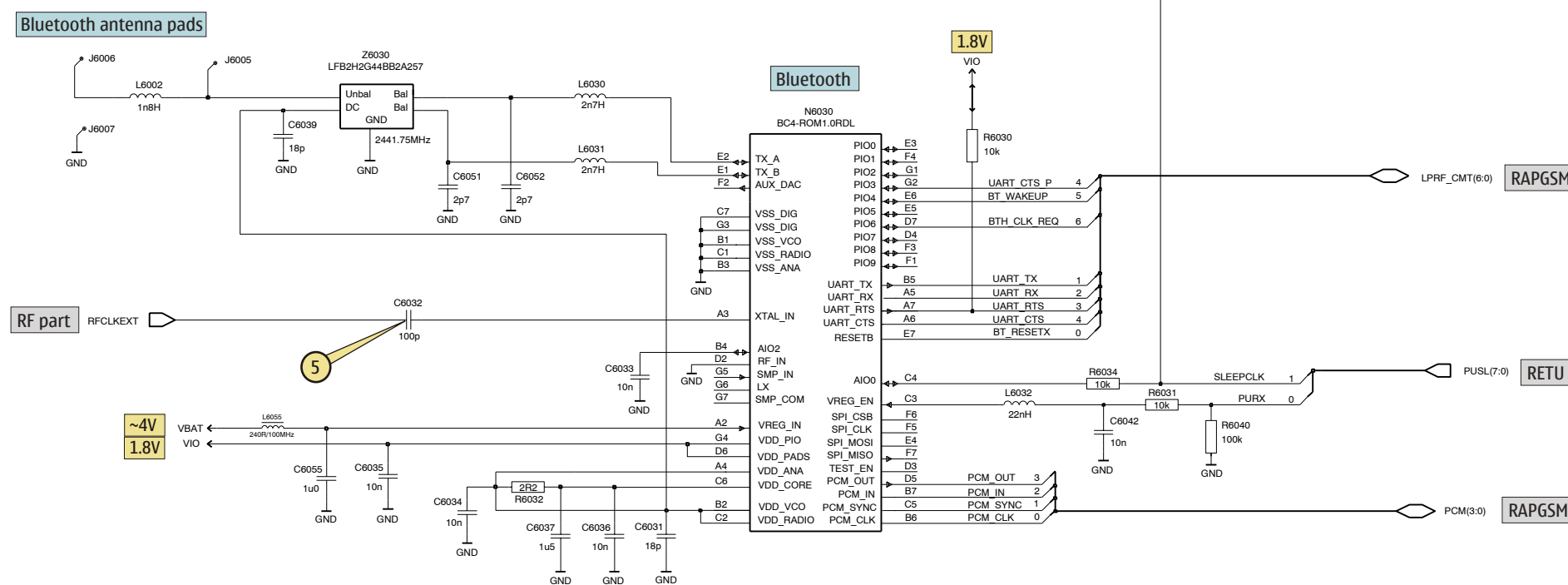

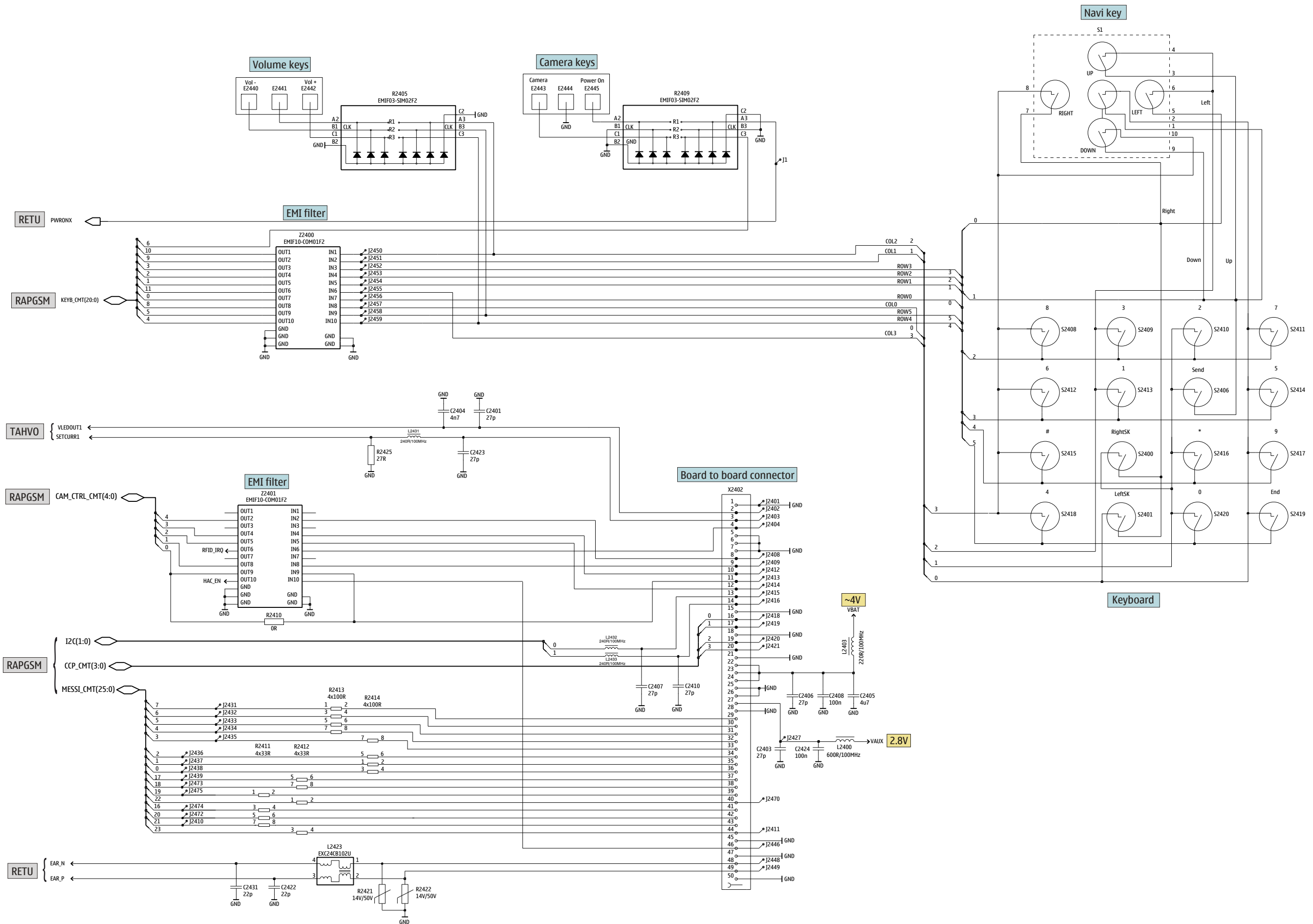

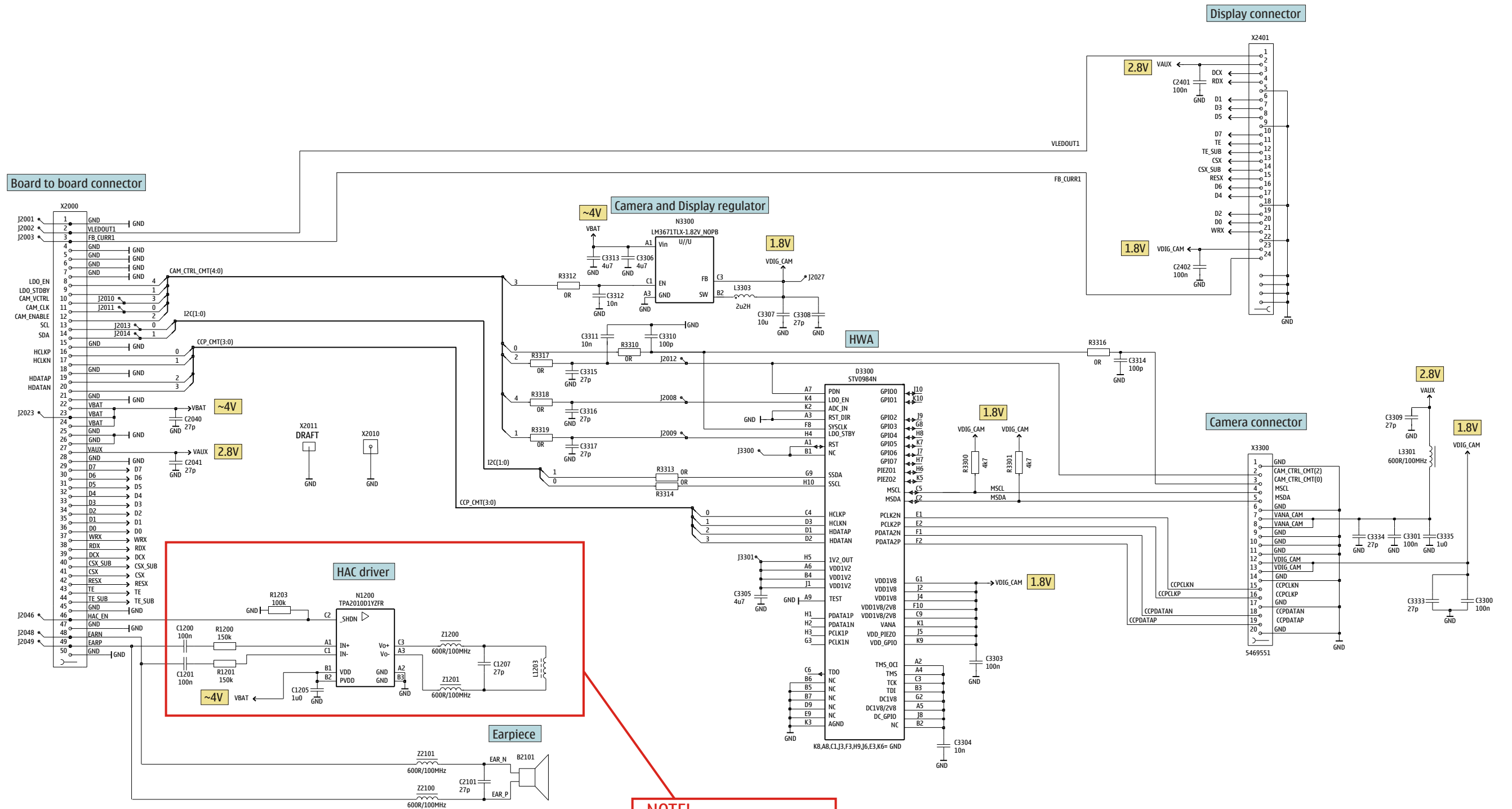

**NOTE!**  
HAC is only included in  
- Nokia 6126h / RM-126  
- Nokia 6133h / RM-126



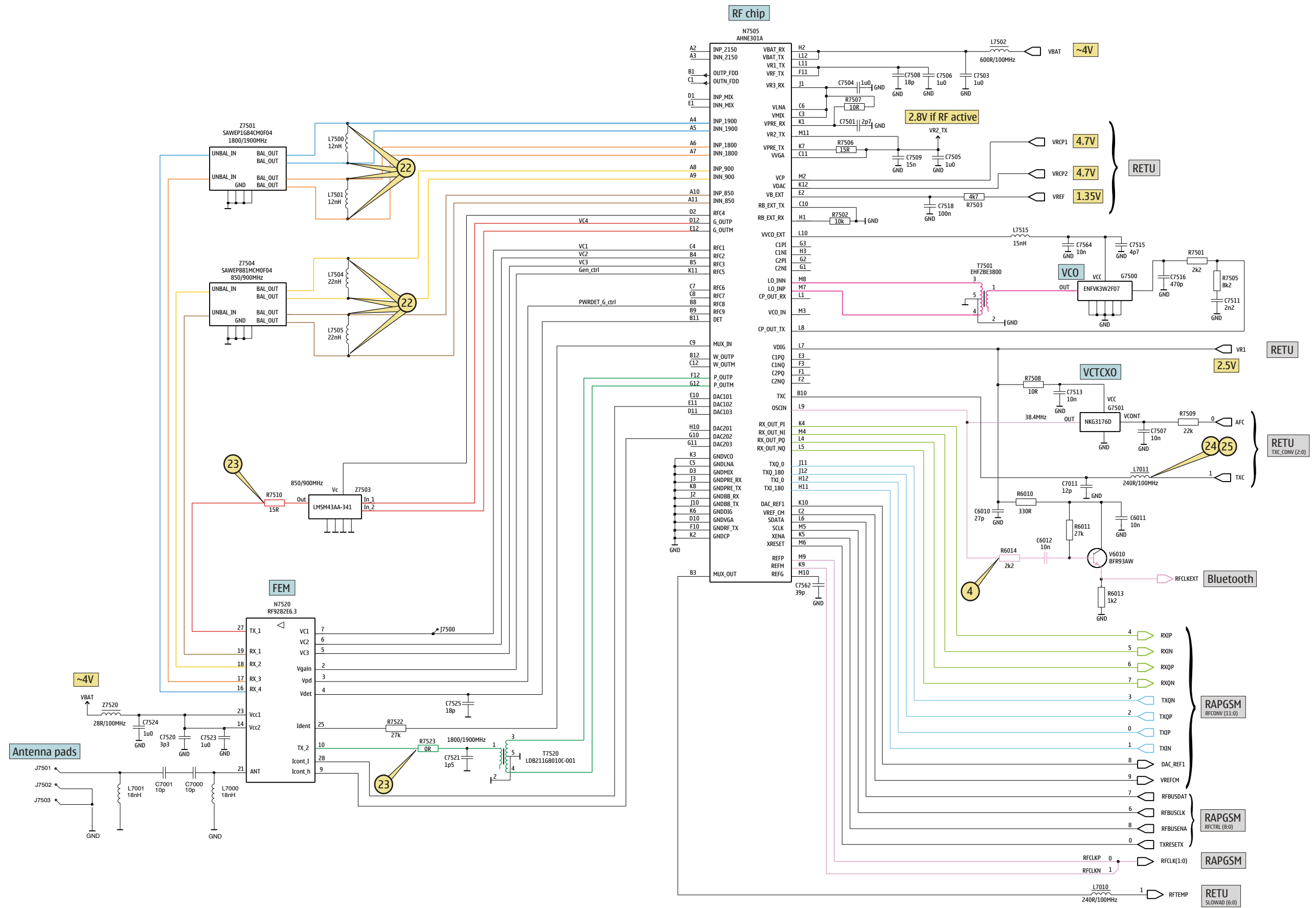

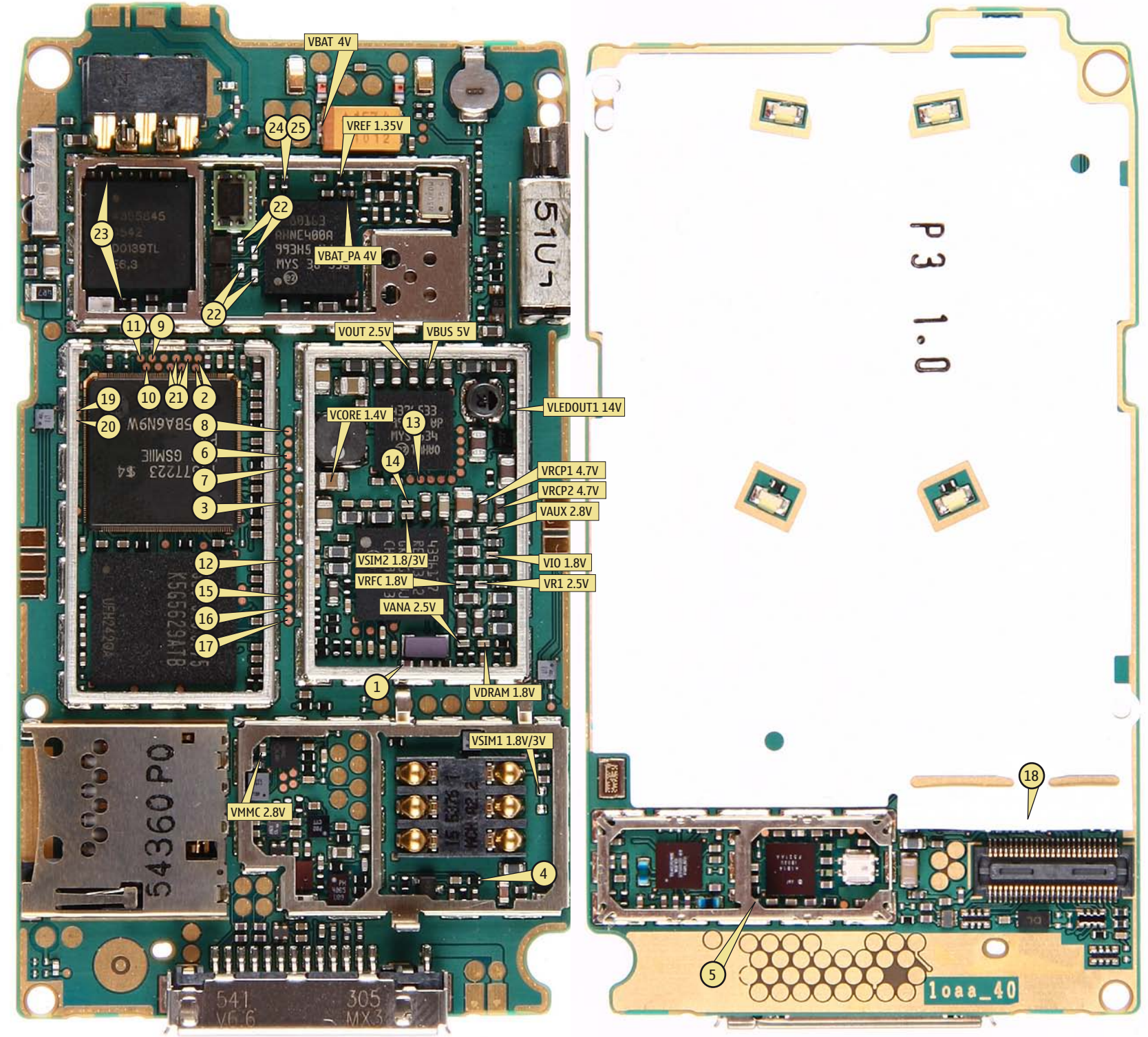
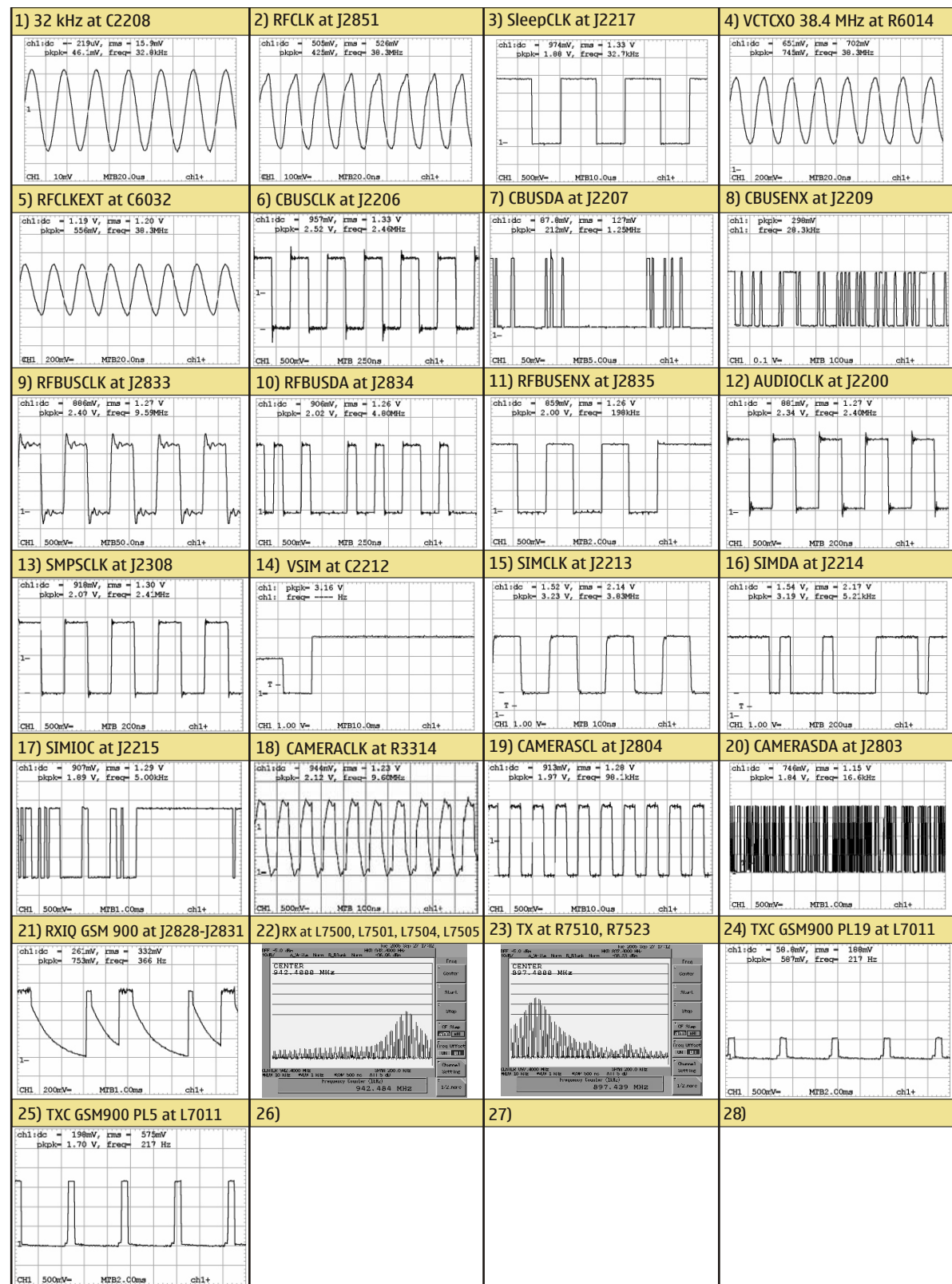

B	C2271	J10	C3007	K9	E	J2409	P9	J3203	M9	R2001	O9	R3004	J8		
B2100	P7	C2272	J10	C3008	J9	E2105	C9	J2410	O9	J6005	P6	R2002	N9	R3200	M9
B2200	K11	C2273	I10	C3009	K9	E2106	C11	J2411	Q10	J6006	P5	R2003	N9	R3201	M9
C	C2274	I11	C3100	L10	E2440	J5	J2412	P10	J6007	P6	R2004	N9	R3202	M9	
C2000	O13	C2275	I10	C3200	M9	E2441	J5	J2413	Q10	J7500	G6	R2005	N9	R3242	L10
C2001	O13	C2281	J12	C3201	M9	E2442	J5	J2414	P10	J7503	B7	R2006	N9	R3243	L9
C2002	N10	C2300	H10	C3202	M9	E2443	J13	J2415	Q11	J7504	B8	R2007	O10	R3312	L9
C2003	N9	C2301	G10	C3210	M9	E2444	I13	J2416	P11	J7505	B6	R2008	O10	R3313	L9
C2004	N9	C2302	I10	C3242	L9	E2445	I13	J2418	N8	L	R2009	O10	R3314	N7	
C2005	P9	C2303	G12	C3303	M9	F	J2419	O8	L2000	O13	R2010	O10	R6010	O12	
C2006	P9	C2304	I11	C6002	P5	F2000	O12	J2420	O8	L2001	P9	R2011	M11	R6011	O11
C2007	N9	C2305	G12	C6003	P5 <th>G</th> <th>J2421</th> <th>O8</th> <th>L2002</th> <th>N9</th> <th>R2070</th> <th>B7</th> <th>R6013</th> <th>O11</th>	G	J2421	O8	L2002	N9	R2070	B7	R6013	O11	
C2008	N9	C2306	G12	C6010	O12	G2200	C12	J2427	P11	L2003	N9	R2100	N10	R6014	O12
C2009	N9	C2307	G11	C6011	O12	G7500	F11	J2431	N5	L2004	O9	R2101	N10	R6015	O11
C2010	N9	C2309	G10	C6012	O12	G7501	D11	J2432	N6	L2108	C10	R2102	M10	R6030	O11
C2011	P8	C2312	G11	C6031	N9 <th>J</th> <th>J2433</th> <th>N6</th> <th>L2109</th> <th>C11</th> <th>R2103</th> <th>M10</th> <th>R6031</th> <th>N10</th>	J	J2433	N6	L2109	C11	R2103	M10	R6031	N10	
C2012	P8	C2313	G11	C6032	O11 <th>J2000</th> <th>P12</th> <th>J2434</th> <th>P10</th> <th>L2202</th> <th>K12</th> <th>R2104</th> <th>F12</th> <th>R6032</th> <th>N11</th>	J2000	P12	J2434	P10	L2202	K12	R2104	F12	R6032	N11
C2013	P9	C2314	H12	C6033	O11 <th>J2001</th> <th>O9</th> <th>J2435</th> <th>P10</th> <th>L2203</th> <th>J12</th> <th>R2105</th> <th>F12</th> <th>R6034</th> <th>O10</th>	J2001	O9	J2435	P10	L2203	J12	R2105	F12	R6034	O10
C2014	P9	C2315	I13	C6034	O10 <th>J2003</th> <th>O9</th> <th>J2436</th> <th>P10</th> <th>L2204</th> <th>K12</th> <th>R2108</th> <th>E12</th> <th>R6036</th> <th>O9</th>	J2003	O9	J2436	P10	L2204	K12	R2108	E12	R6036	O9
C2015	O10	C2316	G13	C6035	N11 <th>J2004</th> <th>O8</th> <th>J2437</th> <th>P9</th> <th>L2205</th> <th>K12</th> <th>R2109</th> <th>F12</th> <th>R6040</th> <th>O9</th>	J2004	O8	J2437	P9	L2205	K12	R2109	F12	R6040	O9
C2016	O10	C2401	N5	C6036	O11 <th>J2005</th> <th>P12</th> <th>J2438</th> <th>P9</th> <th>L2206</th> <th>J12</th> <th>R2114</th> <th>C11</th> <th>R6156</th> <th>N12</th>	J2005	P12	J2438	P9	L2206	J12	R2114	C11	R6156	N12
C2017	O13	C2402	P5	C6037	O11 <th>J2006</th> <th>O8</th> <th>J2439</th> <th>P9</th> <th>L2270</th> <th>J10</th> <th>R2115</th> <th>C11</th> <th>R6159</th> <th>O13</th>	J2006	O8	J2439	P9	L2270	J10	R2115	C11	R6159	O13
C2018	O10	C2403	O8	C6039	O10 <th>J2010</th> <th>P12</th> <th>J2446</th> <th>Q11</th> <th>L2271</th> <th>J10</th> <th>R2200</th> <th>K12</th> <th>R6160</th> <th>O13</th>	J2010	P12	J2446	Q11	L2271	J10	R2200	K12	R6160	O13
C2019	P10	C2404	P5	C6040	N11 <th>J2060</th> <th>M10</th> <th>J2448</th> <th>P11</th> <th>L2272</th> <th>I11</th> <th>R2201</th> <th>L12</th> <th>R6161</th> <th>O12</th>	J2060	M10	J2448	P11	L2272	I11	R2201	L12	R6161	O12
C2070	C10	C2405	N9	C6042	N10 <th>J2070</th> <th>D9</th> <th>J2449</th> <th>P11</th> <th>L2273</th> <th>I10</th> <th>R2202</th> <th>K10</th> <th>R7001</th> <th>C8</th>	J2070	D9	J2449	P11	L2273	I10	R2202	K10	R7001	C8
C2071	B7	C2406	N7	C6051	O10 <th>J2071</th>	J2071	C10	J2450	I13	L2301	G10	R2203	K10	R7501	E11
C2072	M13	C2407	N6	C6052	O10 <th>J2072</th> <th>C9</th> <th>J2451</th> <th>E13</th> <th>L2302</th> <th>H10</th> <th>R2204</th> <th>K10</th> <th>R7502</th> <th>F9</th>	J2072	C9	J2451	E13	L2302	H10	R2204	K10	R7502	F9
C2073	D6	C2408	N8	C6055	O9 <th>J2074</th> <th>D9</th> <th>J2452</th> <th>H13</th> <th>L2304</th> <th>H12</th> <th>R2205</th> <th>K10</th> <th>R7503</th> <th>D10</th>	J2074	D9	J2452	H13	L2304	H12	R2205	K10	R7503	D10
C2074	D6	C2409	D12	C6157	O13 <th>J2075</th> <th>C9</th> <th>J2453</th> <th>E13</th> <th>L2305</th> <th>G12</th> <th>R2206</th> <th>K10</th> <th>R7505</th> <th>E11</th>	J2075	C9	J2453	E13	L2305	G12	R2206	K10	R7505	E11
C2075	D6	C2410	N6	C6158	O13 <th>J2076</th> <th>C10</th> <th>J2454</th> <th>K13</th> <th>L2306</th> <th>G11</th> <th>R2207</th> <th>K10</th> <th>R7506</th> <th>E10</th>	J2076	C10	J2454	K13	L2306	G11	R2207	K10	R7506	E10
C2076	D11	C2420	O7	C6159	N12 <th>J2103</th> <th>P8</th> <th>J2455</th> <th>L13</th> <th>L2307</th> <th>H13</th> <th>R2208</th> <th>K10</th> <th>R7507</th> <th>F10</th>	J2103	P8	J2455	L13	L2307	H13	R2208	K10	R7507	F10
C2080	C9	C2421	O6	C6162	O13 <th>J2104</th> <th>P8</th> <th>J2456</th> <th>L13</th> <th>L2400</th> <th>O8</th> <th>R2209</th> <th>K10</th> <th>R7508</th> <th>E11</th>	J2104	P8	J2456	L13	L2400	O8	R2209	K10	R7508	E11
C2100	N10	C2422	O8	C6163	O12 <th>J2115</th> <th>B10</th> <th>J2457</th> <th>F13</th> <th>L2403</th> <th>N9</th> <th>R2210</th> <th>C12</th> <th>R7509</th> <th>D11</th>	J2115	B10	J2457	F13	L2403	N9	R2210	C12	R7509	D11
C2101	N10	C2423	N5	C6164	N12 <th>J2116</th> <th>B11</th> <th>J2458</th> <th>E13</th> <th>L2423</th> <th>O8</th> <th>R2212</th> <th>J10</th> <th>R7510</th> <th>D6</th>	J2116	B11	J2458	E13	L2423	O8	R2212	J10	R7510	D6
C2102	N10	C2424	O8	C6165	N11 <th>J2200</th> <th>J9</th> <th>J2459</th> <th>D13</th> <th>L2431</th> <th>N2</th> <th>R2213</th> <th>L12</th> <th>R7522</th> <th>D7</th>	J2200	J9	J2459	D13	L2431	N2	R2213	L12	R7522	D7
C2103	M9	C2431	O8	C6167	O12 <th>J2201</th> <th>I9</th> <th>J2460</th> <th>L13</th> <th>L2432</th> <th>N3</th> <th>R2214</th> <th>L12</th> <th>R7523</th> <th>F7</th>	J2201	I9	J2460	L13	L2432	N3	R2214	L12	R7523	F7
C2104	M10	C2600	E6	C6170	O13 <th>J2202</th> <th>J9</th> <th>J2460</th> <th>D13</th> <th>L2433</th> <th>N3</th> <th>R2216</th> <th>L12</th> <th>T</th> <th></th>	J2202	J9	J2460	D13	L2433	N3	R2216	L12	T	
C2108	B10	C2601	F5	C6176	O12 <th>J2203</th> <th>I9</th> <th>J2461</th> <th>L13</th> <th>L3200</th> <th>M9</th> <th>R2250</th> <th>M13</th> <th>T7501</th> <th>E11</th>	J2203	I9	J2461	L13	L3200	M9	R2250	M13	T7501	E11
C2200	J10	C2602	E5	C6178	O12 <th>J2204</th> <th>K10</th> <th>J2470</th> <th>P10</th> <th>L3201</th> <th>M10</th> <th>R2251</th> <th>M13</th> <th>T7520</th> <th>F6</th>	J2204	K10	J2470	P10	L3201	M10	R2251	M13	T7520	F6
C2201	K12	C2603	E5	C6179	O12 <th>J2205</th> <th>K10</th> <th>J2472</th> <th>P8</th> <th>L3202</th> <th>M9</th> <th>R2307</th> <th>F12</th> <th>V</th> <th></th>	J2205	K10	J2472	P8	L3202	M9	R2307	F12	V	
C2202	L13	C2604	C6	C6188	O12 <th>J2206</th> <th>H9</th> <th>J2473</th> <th>P9</th> <th>L6002</th> <th>P6</th> <th>R2400</th> <th>I8</th> <th>V2000</th> <th>O13</th>	J2206	H9	J2473	P9	L6002	P6	R2400	I8	V2000	O13
C2203	K11	C2700	M13	C6189	N12 <th>J2207</th> <th>I9</th> <th>J2474</th> <th>P9</th> <th>L6030</th> <th>O10</th> <th>R2401</th> <th>P6</th> <th>V2302</th> <th>F12</th>	J2207	I9	J2474	P9	L6030	O10	R2401	P6	V2302	F12
C2204	K10	C2701	M13	C6190	N13 <th>J2209</th> <th>H9</th> <th>J2475</th> <th>P8</th> <th>L6031</th> <th>N10</th> <th>R2402</th> <th>D12</th> <th>V2400</th> <th>C10</th>	J2209	H9	J2475	P8	L6031	N10	R2402	D12	V2400	C10
C2205	K10	C2800	I9	C6191	N13 <th>J2210</th> <th>K11</th> <th>J2803</th> <th>H6</th> <th>L6032</th> <th>N10</th> <th>R2403</th> <th>O6</th> <th>V2401</th> <th>E12</th>	J2210	K11	J2803	H6	L6032	N10	R2403	O6	V2401	E12
C2206	K11	C2801	G8	C7000	D8 <th>J2212</th> <th>J9</th> <th>J2804</th> <th>H6</th> <th>L6055</th> <th>O9</th> <th>R2405</th> <th>H5</th> <th>V2402</th> <th>E12</th>	J2212	J9	J2804	H6	L6055	O9	R2405	H5	V2402	E12
C2207	L12	C2802	H9	C7001	C8 <th>J2213</th> <th>K9</th> <th>J2805</th> <th>G7</th> <th>L6156</th> <th>O13</th> <th>R2407</th> <th>D12</th> <th>V2405</th> <th>I11</th>	J2213	K9	J2805	G7	L6156	O13	R2407	D12	V2405	I11
C2208	L11	C2803	I9	C7011	D8 <th>J2214</th> <th>K9</th> <th>J2828</th> <th>G7</th> <th>L6176</th> <th>O12</th> <th>R2408</th> <th>D12</th> <th>V2411</th> <th>C8</th>	J2214	K9	J2828	G7	L6176	O12	R2408	D12	V2411	C8
C2209	L11	C2804	G8	C7501	F10 <th>J2215</th> <th>K9</th> <th>J2829</th> <th>G8</th> <th>L7000</th> <th>D7</th> <th>R2409</th> <th>L13</th> <th>V2412</th> <th>I8</th>	J2215	K9	J2829	G8	L7000	D7	R2409	L13	V2412	I8
C2210	I12	C2805	J6	C7502	D10 <th>J2216</th> <th>I9</th> <th>J2830</th> <th>G7</th> <th>L7001</th> <th>C8</th> <th>R2410</th> <th>N7</th> <th>V6010</th> <th>O11</th>	J2216	I9	J2830	G7	L7001	C8	R2410	N7	V6010	O11
C2211	I12	C2807	G9	C7503	D11 <th>J2217</th> <th>I9</th> <th>J2831</th> <th>G8</th> <th>L7010</th> <th>F9</th> <th>R2411</th> <th>O6</th> <th>X</th> <th></th>	J2217	I9	J2831	G8	L7010	F9	R2411	O6	X	
C2212	I11	C2808	H9	C7504	F10 <th>J2218</th> <th>H9</th> <th>J2832</th> <th>G7</th> <th>L7011</th> <th>E9</th> <th>R2412</th> <th>N7</th> <th>X2000</th> <th>P12</th>	J2218	H9	J2832	G7	L7011	E9	R2412	N7	X2000	P12
C2213	J12	C2809	H9	C7505	E11 <th>J2219</th> <th>I9</th> <th>J2833</th> <th>G7</th> <th>L7500</th> <th>F9</th> <th>R2413</th> <th>O8</th> <th>X2001</th> <th>P9</th>	J2219	I9	J2833	G7	L7500	F9	R2413	O8	X2001	P9
C2214	J12	C2810	I9	C7506	D11 <th>J2220</th> <th>J9</th> <th>J2834</th> <th>G7</th> <th>L7501</th> <th>F8</th> <th>R2414</th> <th>P6</th> <th>X2060</th> <th>M13</th>	J2220	J9	J2834	G7	L7501	F8	R2414	P6	X2060	M13
C2215	J12	C2811	J6	C7507	D11 <th>J2221</th> <th>J9</th> <th>J2835</th> <th>G7</th> <th>L7502</th> <td>D10</td> <th>R2417</th> <th>M13</th> <th>X2070</th> <th>C7</th>	J2221	J9	J2835	G7	L7502	D10	R2417	M13	X2070	C7
C2216	J12	C2812	H9	C7508	D10 <th>J2222</th> <th>C13</th> <th>J2851</th> <th>G8</th> <th>L7503</th> <th>D7</th> <th>R2420</th> <th>N6</th> <th>X2402</th> <th>O6</th>	J2222	C13	J2851	G8	L7503	D7	R2420	N6	X2402	O6
C2217	K12	C2813	G6	C7509	E10 <th>J2300</th> <th>I11</th> <th>J2852</th> <th>G8</th> <th>L7504</th> <th>E9</th> <th>R2421</th> <th>P5</th> <th>X2700</th> <th>N12</th>	J2300	I11	J2852	G8	L7504	E9	R2421	P5	X2700	N12
C2218	K11	C2814	G9	C7511	E11 <th>J2306</th> <th>D11</th> <th>J3000</th> <th>L8</th> <th>L7505</th> <th>E8</th> <th>R2422</th> <th>O5</th> <th>X3200</th> <th>N7</th>	J2306	D11	J3000	L8	L7505	E8	R2422	O5	X3200	N7
C2219	K12	C2815	J9	C7513	D11 <th>J2307</th> <th>C11</th> <th>J3001</th> <th>J7</th> <th>L7515</th> <th>F11</th> <th>R2424</th> <th>I11</th> <th>Z</th> <th></th>	J2307	C11	J3001	J7	L7515	F11	R2424	I11	Z	
C2220	I11	C2816	J8	C7515	F11 <th>J2308</th> <th>I11</th> <th>J3002</th> <th>I6</th> <th>M</th> <th>R2425</th> <th>N6</th> <th>Z2000</th> <th>P10</th>	J2308	I11	J3002	I6	M	R2425	N6	Z2000	P10	
C2221	I12	C2818	J7	C7516	F11 <th>J2309</th> <th>H12</th> <th>J3003</th> <th>L7</th> <th>M2100</th> <th>E13</th> <th>R2430</th> <th>N6</th> <th>Z2001</th> <th>P10</th>	J2309	H12	J3003	L7	M2100	E13	R2430	N6	Z2001	P10
C2222	I12	C2819	J8	C7518	D10 <th>J2310</th> <th>H12</th> <th>J3004</th> <th>K8</th> <th>N</th> <th>R2435</th> <th>L6</th> <th>Z2003</th> <th>P10</th>	J2310	H12	J3004	K8	N	R2435	L6	Z2003	P10	
C2223	J10	C2820	G6	C7520	F7 <th>J2311</th> <th>I11</th> <th>J3005</th> <th>J8</th> <th>N2300</th> <th>H11</th> <th>R2440</th> <th>L13</th> <th>Z2400</th> <th>N8</th>	J2311	I11	J3005	J8	N2300	H11	R2440	L13	Z2400	N8
C2224	K10	C2821	G7	C7521	F7 <th>J2312</th> <th>I12</th> <th>J3006</th> <th>J8</th> <th>N2301</th> <th>H12</th> <th>R2441</th> <th>L13</th> <th>Z2401</th> <th>N6</th>	J2312	I12	J3006	J8	N2301	H12	R2441	L13	Z2401	N6
C2225	K12	C2830	G8	C7523	F7 <th>J2313</th> <th>I12</th> <th>J3112</th> <th>L11</th> <th>N2400</th> <th>O7</th> <th>R2600</th> <th>F5</th> <th>Z6030</th> <th>O9</th>	J2313	I12	J3112	L11	N2400	O7	R2600	F5	Z6030	O9
C2226	J12	C2831	G8	C7524	D7 <th>J2314</th> <th>I12</th> <th>J3113</th> <th>L12</th> <th>N2600</th> <th>D5</th> <th>R2700</th> <th>M12</th> <th>Z7501</th> <th>F8</th>	J2314	I12	J3113	L12	N2600	D5	R2700	M12	Z7501	F8
C2227	I11	C3000	K6	C7525	D6 <th>J2315</th> <th>H12</th> <th>J3114</th> <th>L12</th> <th>N3200</th> <th>M9</th> <th>R2701</th> <th>N13</th> <th>Z7503</th> <th>E8</th>	J2315	H12	J3114	L12	N3200	M9	R2701	N13	Z7503	E8
C2228	J12	C3001	K6	C7562	D9 <th>J2316</th> <th>I11</th> <th>J3115</th> <th>L11</th> <th>N6030</th> <th>O10</th> <th>R2801</th> <th>H9</th> <th>Z7504</th> <th>E8</th>	J2316	I11	J3115	L11	N6030	O10	R2801	H9	Z7504	E8
C2229	K12	C3002	K6	C7564	F10 <th>J2401</th> <th>P11</th> <th>J3116</th> <th>L12</th> <th>N6156</th> <th>O12</th> <th>R2803</th>	J2401	P11	J3116	L12	N6156	O12	R2803	I9	Z7520	F7
C2230	K12	C3003	J9 <th>D</th> <th>J2402</th> <th>Q9</th> <th>J3117</th> <th>L11</th> <th>N7505</th> <th>O10</th> <th>R2804</th> <th>I9</th> <th></th> <th></th> <th></th>	D	J2402	Q9	J3117	L11	N7505	O10	R2804	I9			
C2231	I10	C3004	J9	D2200	J11	J2403	Q9	J3200	M9	N7520	E7	R3000	K6		
C2232	J12	C3005	K9	D2800	H7	J2404	P9	J3201	M9	R	R3002	I9			
C2270	J10	C3006	L9	D3000	K7	J2408	Q10	J3202	N9	R2000	O10	R3003	J7		

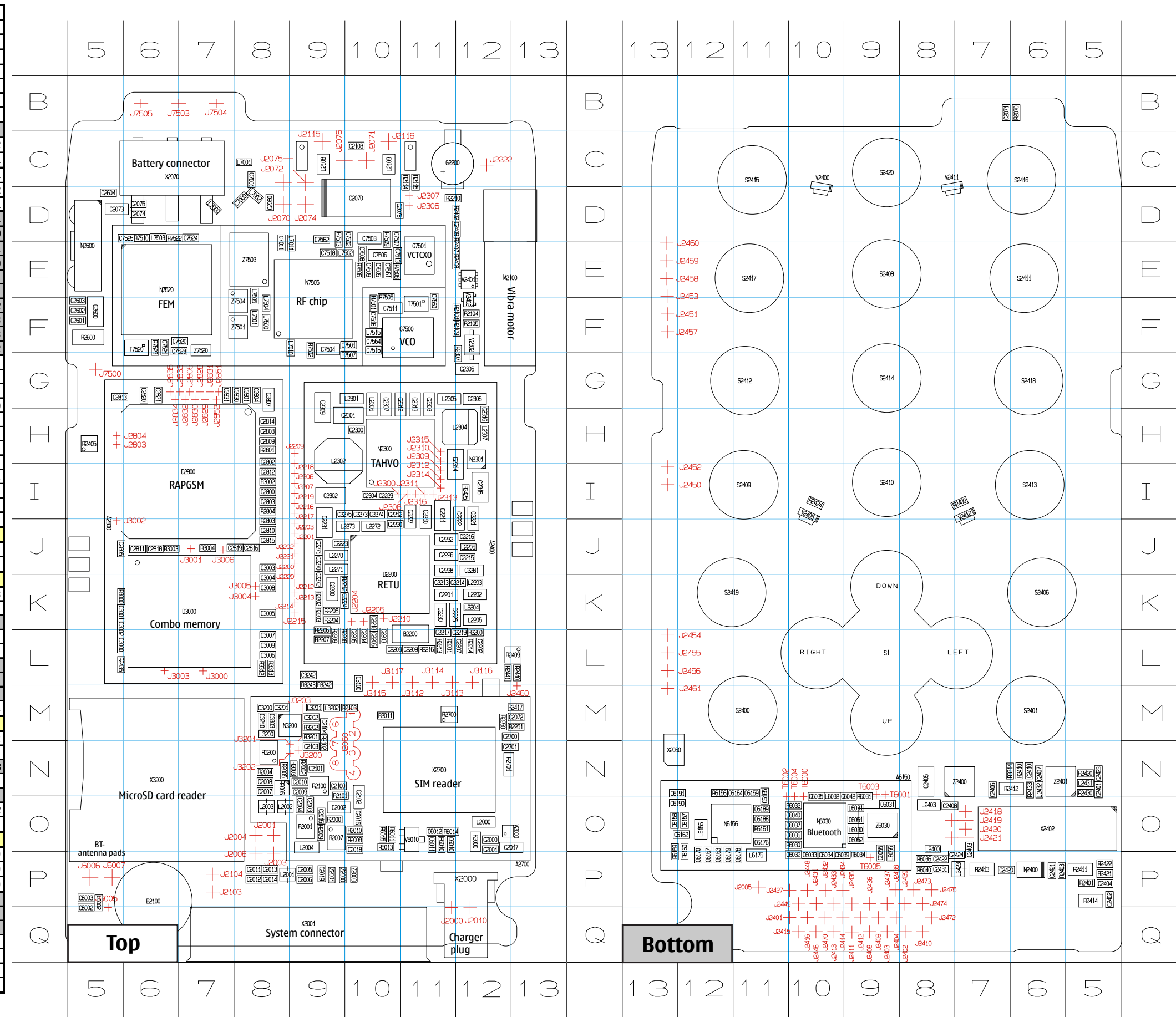

B		N	
B2101	A5	N1200	J8
C		N3300	M1
C1200	J8	R	
C1201	J8	R1200	J8
C1205	K8	R1201	J8
C1207	J8	R1203	K8
C2040	M6	R1204	L8
C2041	L8	R1205	L7
C2101	J8	R2401	B7
C2401	B7	R2402	B8
C2402	B7	R3300	L2
C3300	M3	R3301	L3
C3301	M3	R3304	L1
C3303	M2	R3306	L3
C3304	L3	R3307	L2
C3305	L3	R3310	M2
C3306	L1	R3312	L2
C3307	M1	R3313	M2
C3308	M2	R3314	M2
C3309	M3	R3316	M2
C3310	M2	R3317	M6
C3311	M3	R3318	M6
C3312	L2	R3319	M6
C3313	L1	R3330	M2
C3314	M3	X	
C3315	L6	X2000	M7
C3316	L6	X2010	L8
C3317	L6	X2401	A7
C3333	M3	X3300	M4
C3334	M3	Z	
C3335	N4	Z1200	J8
D		Z1201	J8
D3300	M2	Z2100	J8
L		Z2101	J8
L1203	A2		
L3301	M3		
L3303	M1		

